



KINNEY®

ROTARY PISTON VACUUM PUMPS AND SYSTEMS



TUTHILL
Vacuum & Blower Systems

CONTENTS

Introduction	1
Applications	2
KT Series	4
KT-LP Series	6
KD/KDH Series	8
KC Series	10
KTC Series	12
Options and Accessories	Back Page Flap

PROFILE OF OUR CAPABILITIES

Two years after it was founded in 1902, Kinney introduced the world's first rotary pump. Then in 1926, Kinney developed a vacuum pump for use in large commercial operations. Just as these pumps helped change the face of America by making it possible to mass produce products such as light bulbs, radio tubes, refrigerator and air conditioner components, constant research and innovative manufacturing techniques has continued to spearhead Kinney's leadership in the design and manufacture of **oil-sealed rotary piston vacuum pumps**.

And today, the remarkable long life and reliability of Kinney pumps is testimony to the soundness of the basic rotary piston principle with the elimination of metal-to-metal contact in the pumping chamber.

The Kinney line of oil-sealed piston pumps covers a wide range of sizes in both single stage and compound pump design and as part of Tuthill Vacuum & Blower Systems, our full line capability lets us service a host of major industries worldwide (see Application chart on pages 4-5). Our wide selection offers Kinney customers a highly reliable, single source for pumps as well as their installation, service and technical know-how. You can rely on the Kinney line!

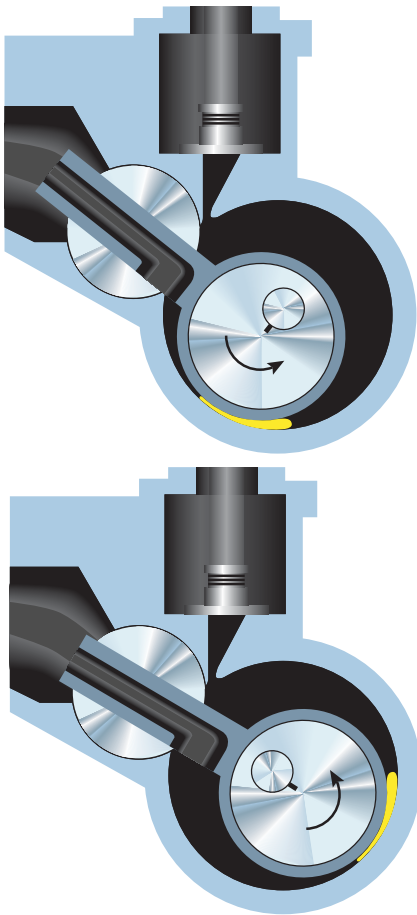

PRINCIPLES OF OPERATION

The Efficiency and Long-Term Reliability of the Kinney Rotary Piston Pump is the Result of the Time-Tested Design.

1. The rotary piston does not spin on its axis. It moves in a circular path within the pumping chamber.
2. As it passes top dead center, it creates a constantly increasing internal space on the inlet or suction side.
3. ...and a constantly decreasing internal space on the pressure or discharge side.
4. A high-integrity seal is maintained between the suction and pressure sides by a film of oil that is captured between the piston and the cylinder.
5. There is no contact between the piston and the cylinder.
6. The oil film is maintained by oil dragged into the clearance by the moving piston which creates a hydrodynamic wedge.
7. At the end of compression cycle, the clearance volume is completely filled with oil, making very high compression ratios available.

These three facts, the oil seal, the filling of the clearance volume, and no contact between piston and wall, are what give the rotary piston pump its low blank off, high pumping speeds at low pressures and great durability.

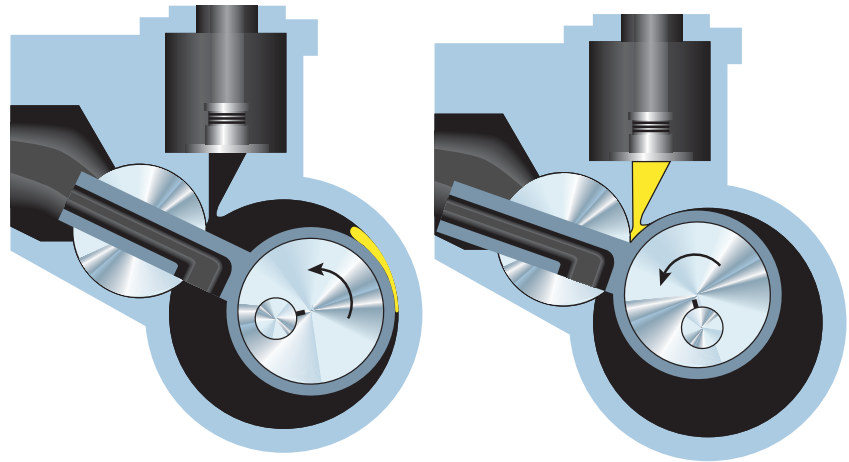

SINGLE-STAGE OR TWO-STAGE PUMPS

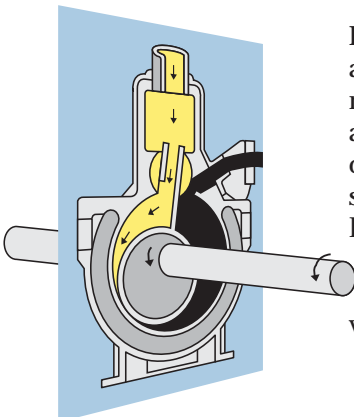

Single-Stage

Depending on your application and what vacuum level you need to attain, Kinney Pumps are available in either single-stage or two-stage design. The two-stage pumps will achieve a lower vacuum level due to the two piston chambers which are arranged in series with a connecting channel.

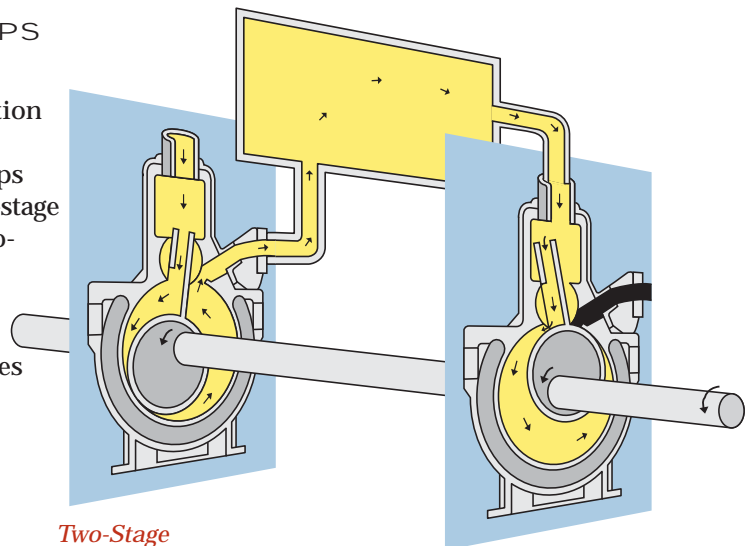

Two-Stage

Kinney oil-sealed vacuum pumps are widely accepted as the standard equipment for applications requiring vacuum over a wide pressure range.

In research and engineering laboratories, Kinney pumps provide the versatility so essential to technological progress.

In production facilities, their ruggedness and compact design permit years of continuous and dependable use.

For the electric power industry, Kinney produces complete vacuum systems, both stationary and portable, air cooled and water cooled, for the evacuation, drying and filling of large transformers, for cable filling, drying and impregnation, and for power station condenser evacuation.

Shown here are a few of the many applications of Kinney vacuum pumps.

Aerospace and Aviation

Evacuation of environmental chambers and test apparatus. Vacuum coating and brazing. Evacuation of cryogenic equipment and vessels.

Agriculture

Vegetable cooling, produce and berry chilling, grain drying, fumigation, tobacco curing, maple syrup gathering.

Air Conditioning and Refrigeration

Kinney offers high vacuum pumps specifically modified for servicing refrigeration equipment including thorough vacuum drying, degassing and fast leak detection. Of special importance to manufacturers of air conditioning and refrigeration equipment is Kinney's wide range of experience in the custom design and manufacture of vacuum pumping carts for production line evacuation and drying of systems and components.

Automotive

Vacuum forming and veneering of interiors, decorative and protective coatings, vacuum filling of cooling and hydraulic systems, lamp production, air conditioning system evacuation, vacuum chucking and lifting, carburetor testing, battery drying, component leak testing, mirror coating.

Biologicals and Drugs

Freeze-drying, distillation and filtration of biologicals, drugs, vitamins and blood plasma.

Chemical Processing

Vacuum dehydration, deaeration, purification, distillation and synthesizing. Vacuum evaporation, drying, concentration, deodorizing and filtration.

Electrical & Electronic

Evacuation of incandescent bulbs, fluorescent, neon, electron and TV tubes, potting of electronic components, production of transistors and other semi-conductor devices. Vacuum coating, crystal growing and impregnation.

Food Processing

Vacuum sealing of bottles, cans and jars, film packaging of meats, poultry and cold cuts, deaeration of beverages, freeze drying of coffee, fruits, vegetables and other food products, vacuum evisceration.

Laboratories

House vacuum systems, chamber evacuation, research and development.

Lasers

Laser cooling and atmosphere control.

Metallurgy

Vacuum degassing, purification, melting, sintering, heat treating, welding, brazing, annealing and impregnation.

Nucleonics

Evacuation of nuclear reactors, accelerators, cyclotrons and bubble chambers.

Paper

Decorative and plastic coating, metallizing.

Petroleum and Petrochemicals

Vacuum distillation and refining, crude yield improvement, oil well evacuation, water deaeration for oil field flooding.

Plastics

Vacuum forming, molding and coating of plastic materials.

Textiles

Vacuum drying, dyeing, material handling and solvent extraction.

Miscellaneous

Water desalinization. Evacuation of chambers used in precision balancing of high-speed rotary components. Freeze drying of museum specimens. Vacuum coating of reflective architectural glass. Evacuation of shock tubes and wind tunnels. Specimen preparation and replication for electron microscopy. Vacuum coating of optical lenses. Evacuation of ballistic ranges.

4 KT SERIES

SINGLE-STAGE ROTARY PISTON VACUUM PUMPS
KT-150, KT-300, KT-500, KT-850

HIGHLIGHTS

- Fuel Pumping Speed Down to 1 Torr
- Operate Continuously at any Pressure up to 100 Torr
- Ultimate Pressure 10 Microns (McLeod Gauge)
- Quiet, Vibration-Free Operation
- Simple Installation. No Special Preparation Necessary
- No Metal-to-Metal Contact in Pumping Chamber
- Adjustable Gas Ballast Permits Handling of Condensable Vapors
- Unequalled Durability Even in Dirty Applications

Typical Applications: Vacuum Packaging, Vacuum Furnaces, Vacuum Coating



SPECIFICATIONS

MODEL		KT-150	KT-300	KT-500	KT-850
Nominal Displacement at Rated RPM	cfm/m ³ /hr	150/255	300/505	490/840	780/1325
Motor HP	hp/kw	7.5/6	15/11	30/22	40/30
Oil Capacity	gal/ltr	6/23	10/38	15/57	28/106
Cooling Water (min) @ 60°F (16°C) @45PSI (max)	gpm/lpm	1/4	2/6	3/9	4/13
Weight (Complete Pump Assy) - Dry	lbs/kg	800/364	1525/693	2700/1225	4400/1996
Maximum Gas Ballast Flow		10%	5%	5%	5%
Typical Blank-off Pressure with 5% GB	Torr/mbar	2.0/3.0	2.0/3.0	2.0/3.0	2.0/3.0
Ultimate Pressure (McLeod Gauge)	Torr/mbar	0.010/0.013	0.010/0.013	0.010/0.013	0.010/0.013
Typical Noise Level @ 10 Torr	dBA	71	72	73	75

All specifications and dimensions subject to change without notice.

PLUS FEATURES

TRIPLEX DESIGN MEANS VIRTUALLY VIBRATION-FREE OPERATION



Kinney KT Pumps have three sets of cams and pistons driven by a common shaft. One cam and piston set is no longer than the other two and the cams are set 180° apart. The dynamic forces produced by the rotation of the long cam

and piston are balanced by opposing forces produced by the short cams and pistons on either side. The resulting out-of-balance force is very small, making it possible to mount the pump on springs or vibramounts which substantially reduce the dynamic forces transmitted to the floor.

HIGH PRESSURE OIL PUMPS ASSURE PROPER LUBRICATIONS
Pumps are lubricated by forced oil feed at all pressures. This forced feed ensures constant oil flow even at high suction pressures.



NO ANCHOR BOLTS
KT Pumps do not require lagging, anchor bolts or special foundations and may be located on any floor that will support their weight.

See back page flap for Options and Accessories

DIMENSIONS
KT-150, KT-300, KT-500, KT-850

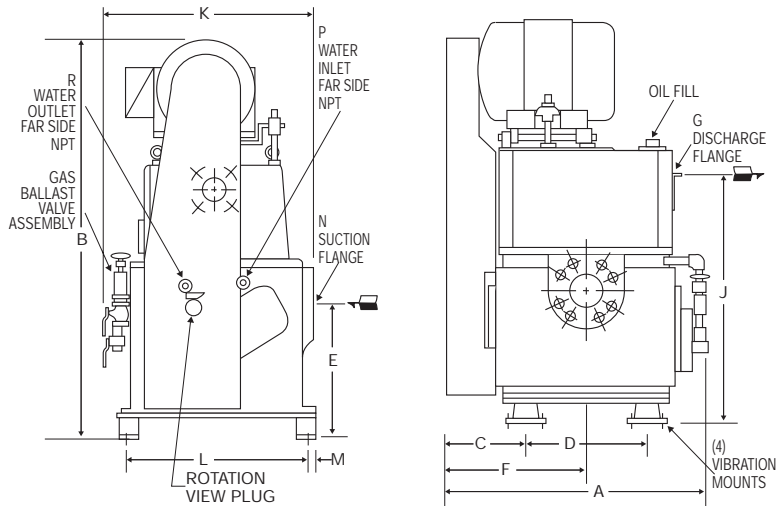

DIMENSIONS (Inches/Millimeters)

MODEL	A	B	C	D	E	F	G	J	K	L	M	N	P	Q	R
KT-150C	26.00 660	43.00 1092	8.63 219	11.75 298	12.63 321	14.50 368	2" ANSI 673	26.50 673	22.75 578	19.13 486	1.19 30	3" ANSI	1/4	9.38 238	3/8
KT-300D	33.50 851	51.25 1302	11.00 267	15.00 381	16.00 406	18.50 470	3" ANSI	32.50 826	23.19 589	22.50 572	1.69 43	4" ANSI	3/8	12.38 314	1/2
KT-500D	37.25 946	63.13 1604	11.75 298	17.00 432	21.50 546	21.25 540	4" ANSI	41.00 1041	32.32 821	28.00 711	1.31 33	6" ANSI	3/8	15.38 391	1/2
KT-850D	48.50 1232	69.50 1765	13.38 340	24.75 629	24.25 616	25.75 654	5" ANSI	46.00 1168	37.25 946	33.00 838	1.38 29	8" ANSI	3/8	18.25 464	1/2

The above table is not for construction purposes.
 Consult TVBS for certified drawings.

PERFORMANCE CURVES

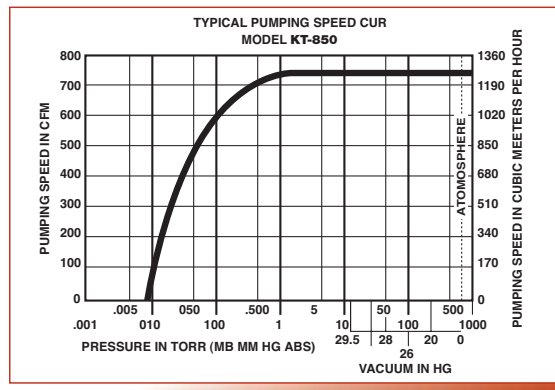
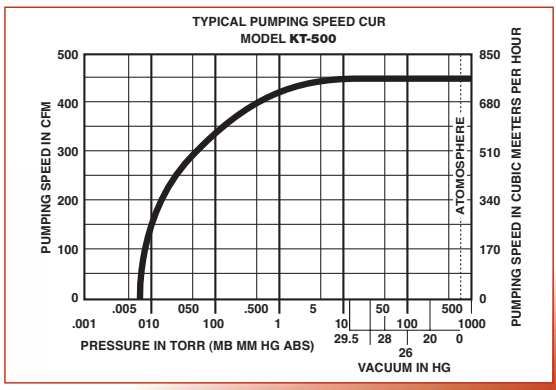
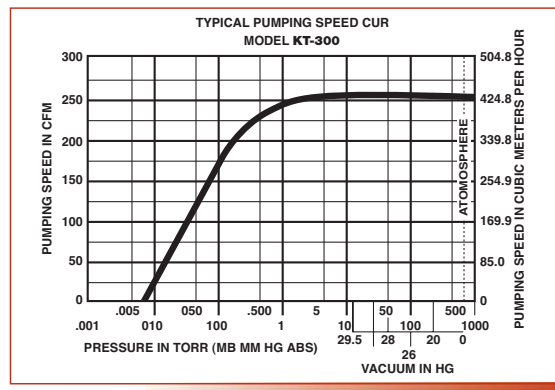
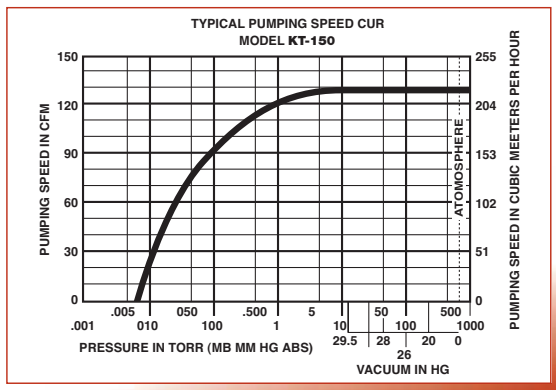

6 KTLP SERIES

OIL-SEALED ROTARY PISTON PUMPS

KT-170 LP, KT-275 LP, KT-505 LP,
KT-840VFP, KT-1350VFP

HIGHLIGHTS

- Quiet, Vibration Free
- No Metal-to-Metal Contact
- Ultimate Pressure to 10 microns
- Full Pumping Speed Down to 1 Torr
- Compact Design, Easy Access for Maintenance
- Simple Installation



Typical Applications: Vacuum Packaging,
Vacuum Furnaces, Vacuum Coating

SPECIFICATIONS

MODEL		KT-170 LP	KT-275 LP	KT-505 LP	KT-840 VFP	KT-1350 VFP
Nominal Displacement at Rated RPM	cfm/m ³ /hr	100/170	162/275	300/505	490/840	780/1325
Motor HP	hp/kw	5/3.7	10/7.5	15/11	30/22	40/30
Normal Pump Rotation	rpm	1150	1200	870	744	581
Oil Capacity	gal/ltr	2.6/10	4.5/17	10/38	15/57	28/106
Cooling Water (min) @ 60°F (16°C) @45PSI (max)	gpm/lpm	1/4	1/4	2/6	3/9	4/13
Weight (Complete Pump Assy) - Dry	lbs/kg	750/340	900/408	1870/848	3650/1660	4375/1959
Maximum Gas Ballast Flow		10%	10%	5%	5%	5%
Typical Blank-off Pressure with 5% GB	Torr/mbar	2.0/3.0	2.0/3.0	2.0/3.0	2.0/3.0	2.0/3.0
Ultimate Pressure (McLeod Gauge)	Torr/mbar	0.010/0.013	0.010/0.013	0.010/0.013	0.010/0.013	0.010/0.013
Typical Noise Level @ 10 Torr	dBA	71	72	72	73	75

All specifications and dimensions subject to change without notice.

PLUS FEATURES

TRIPLEX DESIGN MEANS VIRTUALLY VIBRATION-FREE OPERATION



Kinney KT Pumps have three sets of cams and pistons driven by a common shaft. One cam and piston set is no longer than the other two and the cams are set 180° apart. The dynamic forces produced by the rotation of the long cam

and piston are balanced by opposing forces produced by the short cams and pistons on either side. The resulting out-of-balance force is very small, making it possible to mount the pump on springs or vibramounts which substantially reduce the dynamic forces transmitted to the floor.

See back page flap for Options and Accessories

HIGH PRESSURE OIL PUMPS ASSURE PROPER LUBRICATIONS

Pumps are lubricated by forced oil feed at all pressures. This forced feed ensures constant oil flow even at high suction pressures.



NO ANCHOR BOLTS
KT Pumps do not require lagging, anchor bolts or special foundations and may be located on any floor that will support their weight.

DIMENSIONS

KT-170 LP, KT-275 LP, KT-505 LP

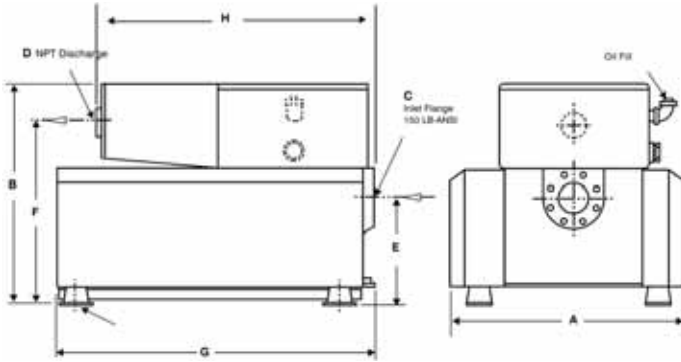

KT-840 VFP, KT-1350 VFP

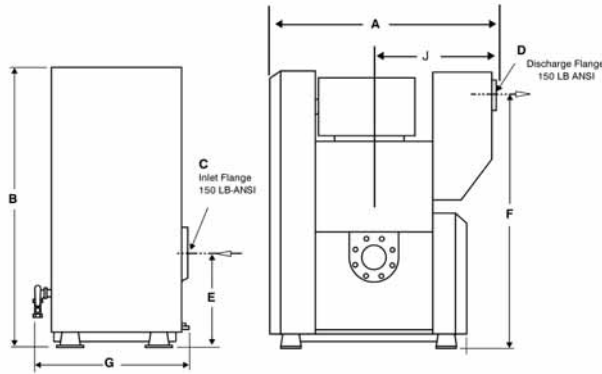

PERFORMANCE CURVES

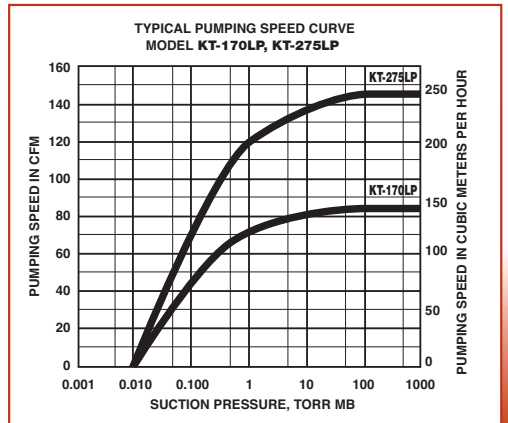
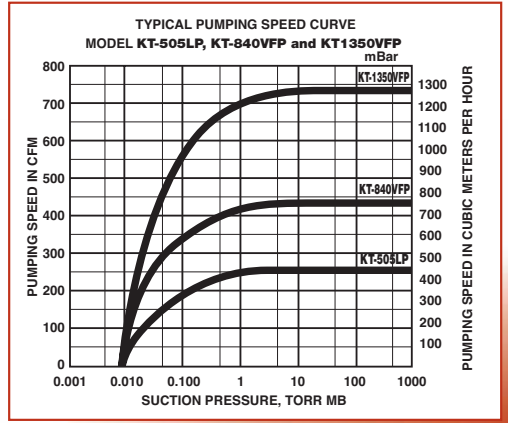

DIMENSIONS (Inches/Millimeters)

MODEL	A	B	C		E	F	G	H	J
			Inlet	Discharge					
KT-170LP	24.75 629	24.63 626	3" NPT	2" NPT	13 330	21 533	37.25 946	36.19 919	—
KT-275LP	28 711	25.5 648	3" ANSI	2" NPT	13.75 349	21.75 552	40.5 1029	35 889	—
KT-505LP	35.25 895	33.88 861	4" ANSI	3" NPT/ 3" ANSI	16.75 425	28.25 699	48.50 1232	44.25 1124	—
KT-840VFP	50 1270	67 1702	6" ANSI	4" ANSI	21 533	61.25 1556	33 838	15.38 391	28.50 724
KT-1350VFP	59 1499	77.75 1975	8" ANSI	5" ANSI	24.25 616	68.75 1746	39.38 1000	18.25 464	32.13 816

STRONGER 4-PIECE CAGED SLIDE PINS

Slide pins in all Kinney Rotary Piston Pumps have 4-pieced caged construction, with end pieces that keep both segments in perfect alignment.



INTEGRAL OIL-MIST-ELIMINATOR CONVERSES OIL, PROVIDES CLEAN DISCHARGE

All Kinney KT Series Low Profile Pumps have as standard an integral three-stage oil-mist-eliminator, which captures and returns the oil to the oil reservoir.

The first stage is an impingement umbrella on which the largest oil droplets are removed. The second stage is a stainless steel pad, which collects small droplets. The third and final stage is a coalescing filter of glass fibers which removes all visible oil smoke from the discharge gas. Oil collected from all three stages automatically drains back to the oil reservoir.

8 KD/KDH SERIES

OIL-SEALED SINGLE-STAGE
ROTARY PISTON VACUUM PUMPS
KD-30, KD-50, KDH-130, KDH-150

HIGHLIGHTS

- Can Operate at any Pressure up to Atmosphere
- Absolute Pressure Down to the Low Micron Range. Ultimate Pressure of 10 Microns HG ABS or Less (McLeod Gauge)
- High Resistance to Abrasion and Corrosion
- No Small Orifices to Plug Up
- Adjustable Gas Ballast Permits Handling of Condensable Vapors

Typical Applications: Drying Chambers, Degassifiers, Filling Machines, Evacuating Process Chambers

Models KD and KDH are single stage vacuum pumps of "duplex" design. Each has a single shaft with two sets of cams and pistons mounted 180° apart, which operate in parallel. The rotary pistons do not touch the walls of the pumping chambers but are sealed by oil, which acts as both a lubricant and a sealant. KD pumps are air-cooled; KDH pumps need water cooling for most applications.



These are other quality features: a controllable gas ballast to permit the handling of condensable vapors and to minimize oil changes due to vapor contamination of the sealing oil. Models KD-30 and KD-50 are equipped with an oil mist eliminator, optional on model KDH-130 & KDH-150. Each pump operates within the rating of its standard TEFC motor throughout the entire operating pressure range.

SPECIFICATIONS

MODEL		KD-30	KD-50	KDH-130	KDH-150
Nominal Displacement at Rated RPM	cfm/m ³ /hr	33/56	52/88	134/227	165/280
Motor HP	hp/kw	1.5/1	2/1.5	5/3.7	7.5/5.6
Normal Pump Rotation	rpm	571	900	546	685
Oil Capacity	gal/ltr	1/3.8	3/11.4	6/22.7	6/22.7
Cooling Water (min) @ 60°F (16°C)	gpm/lpm	AC	AC	.75/3	.75/3
Weight (Complete Pump Assy) - Dry	lbs/kg	200/91	230/104	755/331	840/381
Maximum Gas Ballast Flow		8%	6%	6%	6%
Typical Blank-off Pressure with 5% GB	Torr/mbar	1.5/2	1.5/2	1/1.3	1/1.3
Ultimate Pressure (McLeod Gauge)	Torr/mbar	0.010/0.013	0.010/0.013	0.010/0.013	0.010/0.013
Typical Noise Level @ 10 Torr	dBA	75	80	70	72

All specifications and dimensions subject to change without notice.

PLUS FEATURES

HIGH VAPOR HANDLING

Kinney Piston Pumps are equipped with three features to handle high vapor loads.

First, the adjustable gas ballast valve can introduce air to the pumping chamber, which helps prevent vapor from condensing in the pump oil.

Second, Piston Pumps have a large oil capacity, which has a higher tolerance to contamination. The large reservoir can collect a significant volume of condensed liquid, which can be drained from the pump.

Third, Piston Pumps can operate as part of a vapor handling system, in which the oil reservoir is maintained under vacuum. This is made possible by the oil pump and the design of the oil reservoir to operate under vacuum. Vapor handling systems, which keep the oil dry, can operate in corrosive applications.

STRONGER 4-PIECE CAGED SLIDE PINS

Slide pins in all Kinney Rotary Piston Pumps have 4-pieced caged construction, with end pieces that keep both segments in perfect alignment.



See back page flap for Options and Accessories

KD/KDH SERIES 9

DIMENSIONS
KD-30, KD-50

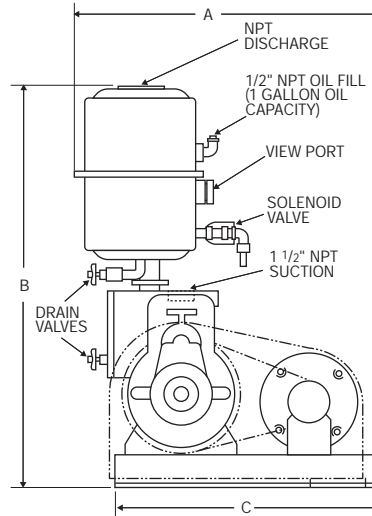
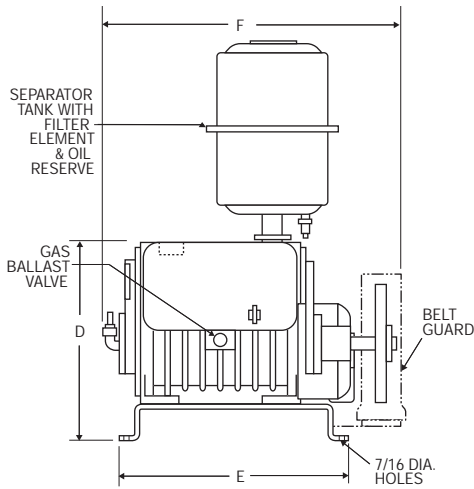

KDH-130, KDH-150

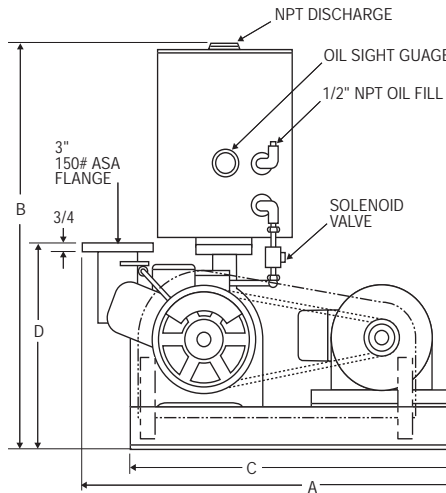
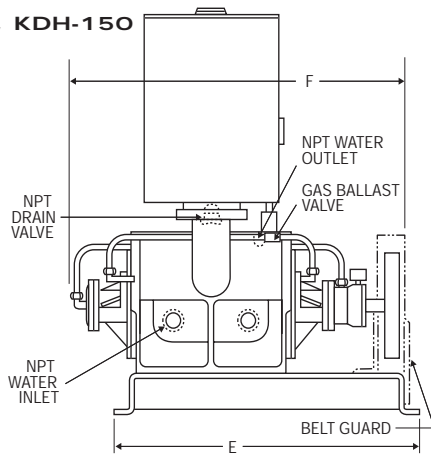

DIMENSIONS (Inches/Millimeters)

MODEL	A	B	C	D	E	F
KD-30	27 7/8 518	27 686	24 1/2 432	12 7/8 327	17 3/8 400	20 508
KD-50	28 5/8 727	32 1/2 826	24 1/2 622	12 7/8 327	17 3/8 441	20 508
KDH-130, KDH-150	38 7/8 987	39 1/4 997	33 5/8 854	20 508	30 13/16 783	28 5/16 719

PERFORMANCE CURVES

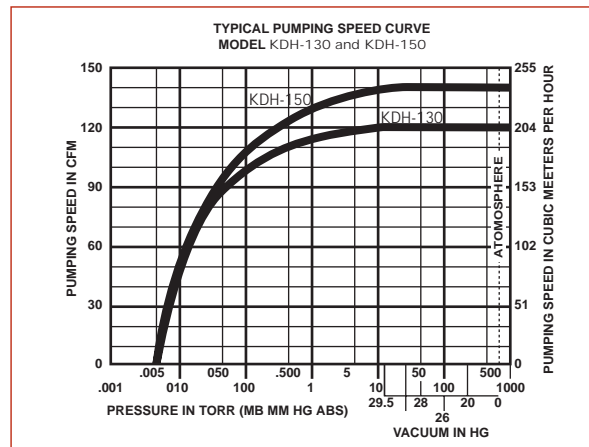
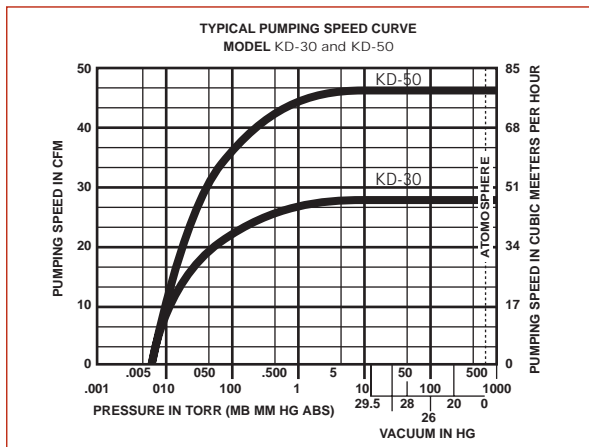

10 KC SERIES

OIL SEALED TWO-STAGE ROTARY
PISTON VACUUM PUMPS
KC-5, KC-8, KC-15

HIGHLIGHTS

- Pumping Speed at Pressures Below 10 Microns. Lower than Attainable with Single-Stage Pumps
- Ultimate Pressure: .2 Microns (McLeod Gauge)
- Can Operate at Any Pressure up to Atmosphere
- Adjustable Gas Ballast Permits Handling of Condensable Vapors
- No Metal-to-Metal Contact in Pumping Chamber
- Unequaled Durability, Even in Dirty Applications
- Air-Cooled

Typical Applications: Refrigeration Systems, Liquid Gas Storage, Automotive Applications, Leak Detection

Kinney Series, two-stage vacuum pumps, are designed to achieve lower pressures than can be achieved with single-stage pumps. Two sets of cams and pistons, mounted 180° apart on a single shaft, operate in series. The two pumping chambers are connected by a channel, which serves as an oil supply duct for the high vacuum side of the pump and as a gas duct between the two stages. The high vacuum side is continuously sealed with vacuum oil from its own reservoir, the vacuum conditioning being provided by the roughing (2nd) stage.

Functionally vibrationless, they are well suited for portable installations. Because there is no metal



contact between the pump piston and cylinder, clearances are sealed and lubricated with oil. Units are equipped with a gas ballast valve to provide vapor-handling capability. Oil mist eliminators are standard. Each pump operates within the rating of its standard TEFC motor throughout its operating pressure range.

Wear is minimum. Units operate without repairs for many years. Pumps can be serviced easily in the field without special tools.

Specifically manufactured refrigeration units prepared for use with POE oil, compatible with Freon R134A are also available.

SPECIFICATIONS

MODEL		KC-5	KC-8	KC-15
Nominal Displacement at Rated RPM	cfm/m ³ /hr	5/8.5	8/13.6	15/25.5
Motor HP	hp/kw	.33/.25	.5/.38	1/.75
Normal Pump Rotation	rpm	638	1022	571
Oil Capacity	qts/ltr	0.8/.76	0.8/.76	3/2.8
Weight (Complete Pump Assy) - Dry	lbs/kg	115/52	120/54	210/95
Maximum Gas Ballast Flow		15%	15%	15%
Typical Blank-off Pressure with 5% GB	Torr/mbar	0.020/0.027	0.020/0.027	0.020/0.027
Ultimate Pressure (McLeod Gauge)	microns/mbar	0.2/2.7x10 ⁻⁴	0.2/2.7x10 ⁻⁴	0.2/2.7x10 ⁻⁴
Typical Noise Level @ 10 Torr	dBA	75	78	75

All specifications and dimensions subject to change without notice.

SPECIAL SERVICE PUMPS

Kinney KC series pumps are ideally suited for tough, demanding applications. They can also be ordered for specific, special duty applications.

Refrigeration Service Pumps – these pumps are manufactured and tested using oil and seals which are compatible with the Freon used in refrigeration coils and compressors.

See back page flap for Options and Accessories

Automotive Brake Line Filling Pumps – these pumps are manufactured and tested using oil which is compatible with brake fluid. A special shaft seal design eliminates oil leakage due to brake fluid contamination in the pump.

Industrial Gas Distribution – these pumps are manufactured and tested using oil which is fire resistant.

DIMENSIONS
KC-5, KC-8, KC-15

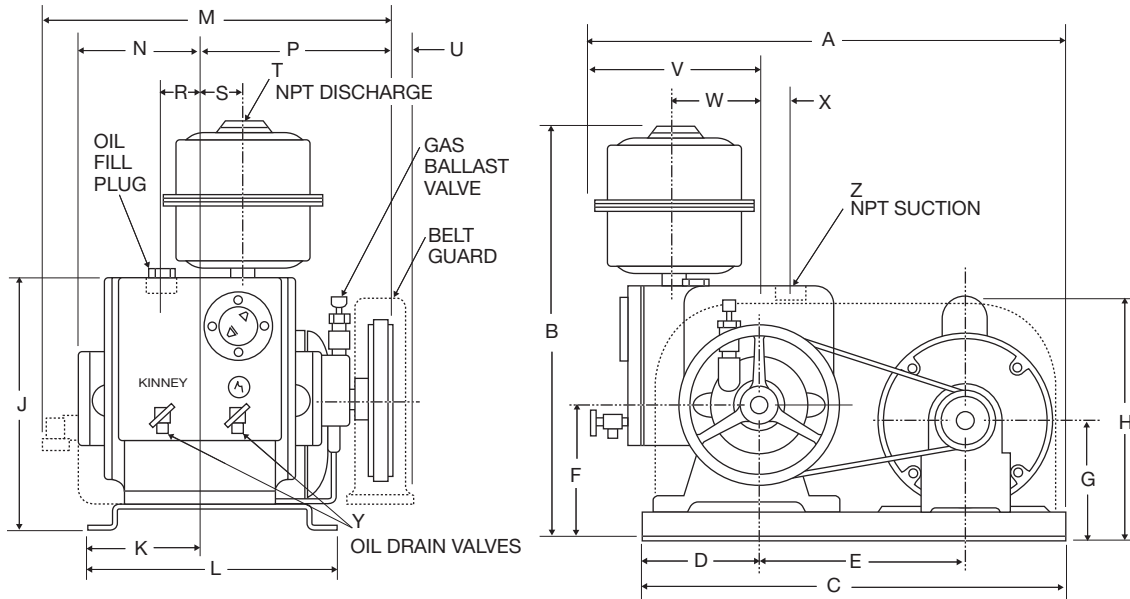

DIMENSIONS (Inches/Millimeters)

MODEL	A	B	C	D	E	F	G	H	J	K	L	M	N
KC-5	18.00 457	17.88 454	16.50 419	4.57 116	8.00 203	5.06 129	4.50 114	(9.88) 251	9.69 246	4.38 111	9.75 248	14.13 359	4.38 111
KC-8	18.00 457	17.88 454	16.50 419	4.57 116	8.00 203	5.06 129	4.50 114	(9.88) 251	9.69 246	4.38 111	9.75 248	14.13 359	4.38 111
KC-15	20.25 514	24.31 617	17.00 432	4.00 101	9.00 229	6.00 152	5.50 140	(10.00) 254	12.81 325	8.00 203	15.75 400	17.94 456	7.25 184

MODEL	P	R	S	T	U	V	W	X	Z	WT. lbs./kg
KC-5	7.50 191	1.50 38	1.75 44	3/4" -	1.00 25	7.13 181	3.13 80	1.19 30	1.00 -	115/52
KC-8	7.50 191	1.50 38	1.75 44	3/4" -	1.00 25	7.13 181	3.13 80	1.19 30	1.00 -	120/54
KC-15	10.69 272	3.00 76	3.50 89	1 1/2" -	0.56 14	7.25 184	3.75 95	- -	2.00 -	210/95

PERFORMANCE CURVES

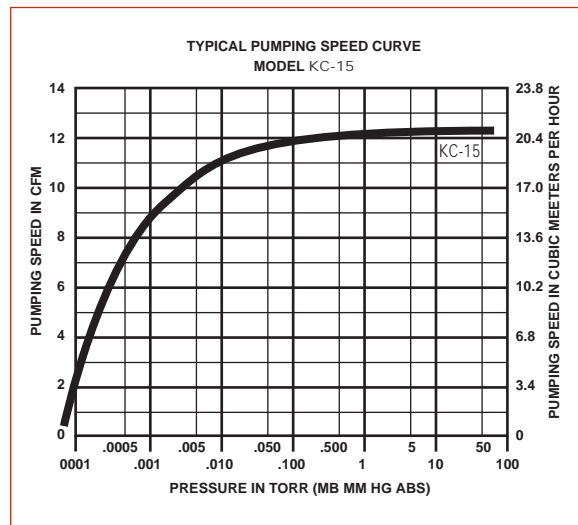
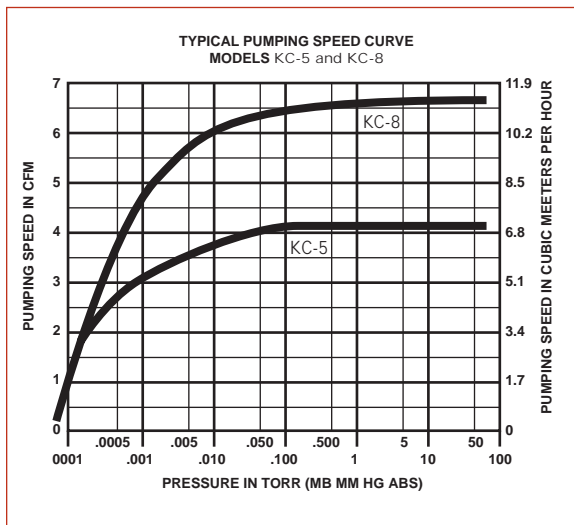

OIL-SEALED TWO-STAGE ROTARY PISTON VACUUM PUMPS

KTC-21, KTC-60, KTC-112

HIGHLIGHTS

- Triplex Piston Design for Quiet, Vibration-Free Operation
- High Pumping Speed at Pressure Below 10 Microns, Lower than Attainable with Single-Stage Pumps
- Ultimate Pressure: .2 Microns (McLeod Gauge)
- Can Operate at Any Pressure up to Atmosphere
- Adjustable Gas Ballast Permits Handling of Condensable Vapors
- No Metal-to-Metal Contact in Pumping Chambers
- Unequaled Durability, Even in Dirty Applications

Typical Applications: Brake Filling Systems, Low Pressure Chemical Vapor, Silicon Crystal Growing, Air Conditioning

The KTC series two-stage high vacuum pumps are of "triplex" design, a single shaft with three sets of cams and pistons, one set larger than the other. Pumps in this series maintain lower pressures than are attainable with single-stage pumps. In operation, one of the smaller pumping chambers is in series with (backing) the other two, which function in parallel. A unique internal balancing technique reduces the magnitude of pump movement (deflection) to 0.0002" while simultaneously reducing the dynamic forces transmitted through the flexible mounting pads furnished with each pump to less than one pound. These pumps are vibration-free, air-cooled, (except the KTC-12 which is water-cooled), and equipped with an adjustable gas ballast providing vapor handling capability while reducing oil changes by preventing condensable vapors from contaminating the oil.

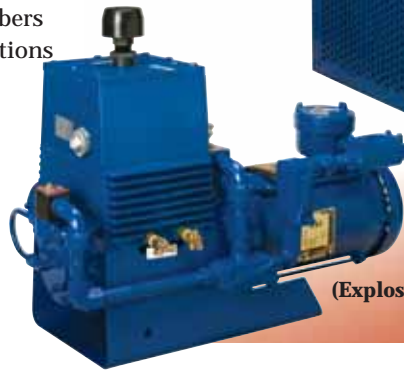

(Explosion proof option shown)



Other superior quality features include a special umbrella type discharge baffle to reduce oil loss to levels not attainable in other pumps, solenoid valves to protect against oil flooding and the single gas ballast adjustment that assures balanced air flow and simple regulation.

The pump operates within the rating of its standard TEFC motor throughout the complete operating pressure range.

SPECIFICATIONS

MODEL		KTC-21	KTC-60	KTC-112
Nominal Displacement at Rated RPM	cfm/m ³ /hr	21/36	60/102	107/182
Motor HP	hp/kw	1.5/1.1	3/2.3	7.5/5.6
Normal Pump Rotation	rpm	1725	972	1055
Oil Capacity	gal/ltr	.5/1.9	2/7.5	4/15
Cooling Water (min) @ 60°F (16°C)	gpm/lpm	AC	AC	1.5/5.5
Weight (Complete Pump Assy) - Dry	lbs/kg	170/77	515/234	765/347
Maximum Gas Ballast Flow		10%	10%	10%
Typical Blank-off Pressure with 5% GB	Torr/mbar	0.020/0.027	0.020/0.027	0.020/0.027
Ultimate Pressure (McLeod Gauge)	microns/mbar	0.2/2.7x10 ⁻⁴	0.2/2.7x10 ⁻⁴	0.2/2.7x10 ⁻⁴
Typical Noise Level @ 10 Torr	dBA	72	70	70

All specifications and dimensions subject to change without notice.

PLUS FEATURES



TRIPLEX DESIGN MEANS VIRTUALLY VIBRATION-FREE OPERATION
Kinney Piston Pumps have three sets of cams and pistons driven by a common shaft. One cam and piston set is no longer than the other two and the cams are set 180° apart. The dynamic forces produced by the rotation of the long cam and piston are balanced by opposing forces produced by the short cams and pistons on either side. The resulting out-of-balance force is very small, making it possible to mount the pump on springs or vibramounts which substantially reduce the dynamic forces transmitted to the floor.

**NO ANCHOR BOLTS**

KT Pumps do not require lagging, anchor bolts or special foundations and may be located on any floor that will support their weight.

See back page flap for Options and Accessories

DIMENSIONS
KTC-21

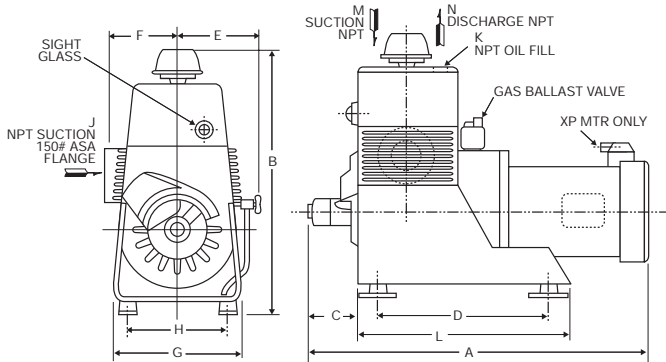

KTC-60, KTC -112

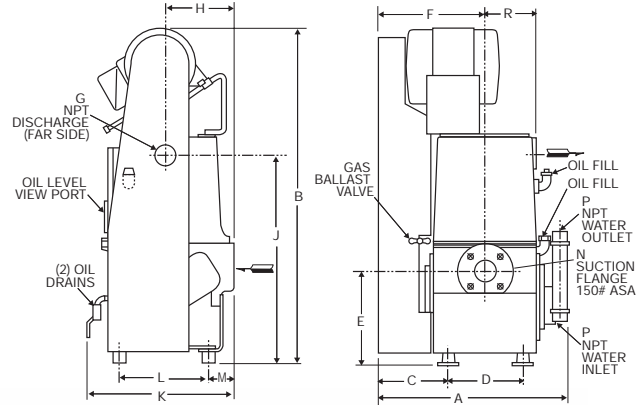

DIMENSIONS (Inches/Millimeters)

MODEL	A	B	C	D	E	F	G	H	J	K	L	M	N	P	R
KTC-21	25 1/8 638	20 1/8 511	2 1/2 64	12 3/8 314	6 1/4 159	5 127	9 9/16 243	7 178	2 -	3/4 -	15 5/8 397	- -	1 NPT	- -	- -
KTC-60	23 1/4 591	36 1/2 927	8 3/4 213	10 254	19 5/8 498	13 3/4 349	1 1/2 NPT	7 5/8 194	21 3/4 552	18 3/4 476	11 1/2 292	2 1/2 64	3 ANSI	- -	6 3/16 159
KTC-112	26 660	43 1092	9 1/2 241	10 254	12 5/8 321	14 1/2 368	2 FLG	9 1/2 241	27 3/8 695	20 3/4 527	12 1/4 311	3 1/8 79	3 ANSI	1/4 NPT	7 178

PERFORMANCE CURVES

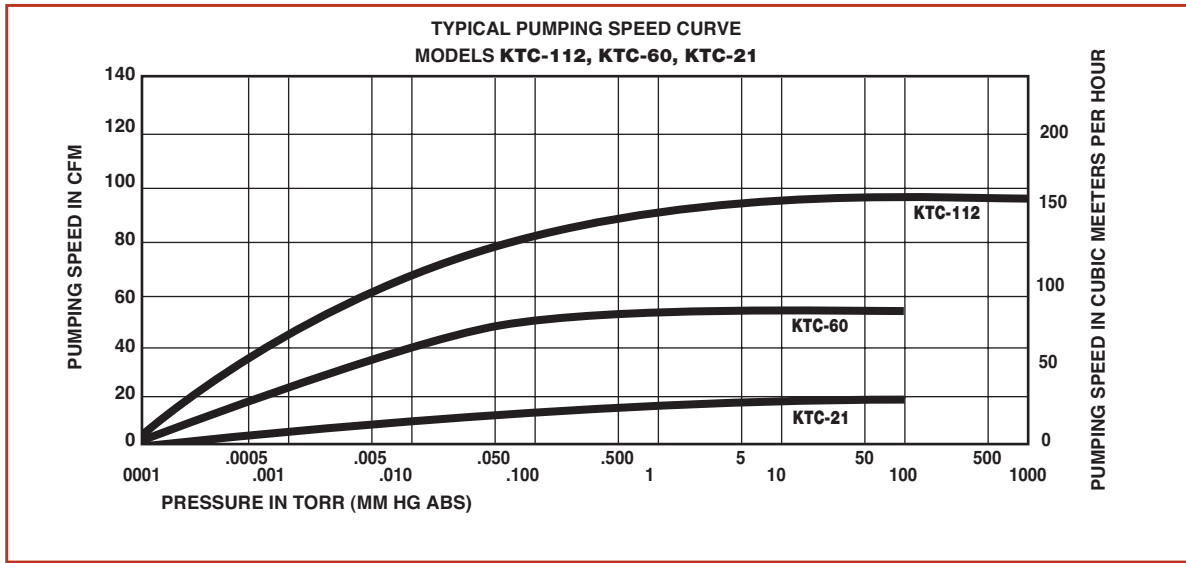

HIGH VAPOR HANDLING

Kinney KT Pumps are equipped with three features to handle high vapor loads.

First, the adjustable gas ballast valve can introduce air to the pumping chamber, which helps prevent vapor from condensing in the pump oil.

Second, KT Pumps have a large oil capacity, which has a higher tolerance to contamination. The large reservoir can collect a significant volume of condensed liquid, which can be drained from the pump.

Third, KT Pumps can operate as part of a vapor handling system, in which the oil reservoir is maintained under vacuum. This is made possible by the oil pump and the design of the oil reservoir to operate under vacuum. Vapor handling systems, which keep the oil dry, can operate in corrosive applications.

STRONGER 4-PIECE CAGED SLIDE PINS

Slide pins in all Kinney Rotary Piston Pumps have 4-pieced caged construction, with end pieces that keep both segments in perfect alignment.



Customized Vacuum Pump Systems

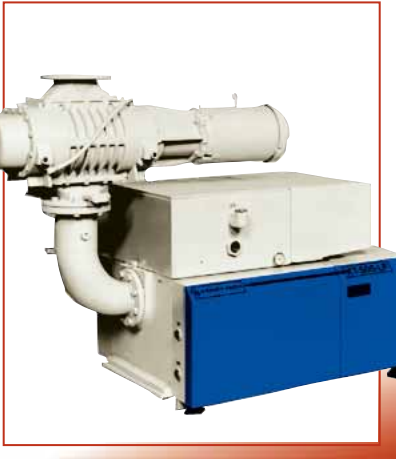

All Kinney Piston Pumps can be combined with booster pumps, liquid ring pumps, or in a variety of customized pumping packages.



Please contact us.

OPTIONS AND ACCESSORIES

CUSTOMIZED OPTIONS

Explosion-proof Motors

All Kinney piston pumps can be equipped with any special motor.



Special Oils

We can manufacture any of our pumps with special, application specific oils.

Pumps will be manufactured from scratch with the precise oil to avoid contamination.



CUSTOM ACCESSORIES

Oil Mist Eliminator

- 99.95% filtering efficiency
- Some w/oil storage capacity & built-in check valve



Oil Filtration System

- Self-priming positive displacement pump
- Welded steel construction
- Epoxy-coated internals
- Variety of filtration element options
- Single or three-stage TEFC motors



Air-cooled Heat Exchanger

- Available for KT & KTC models
- Bronze circulation pump w/closed-coupled TEFC motor
- Interconnection hoses
- Single or three-stage models available



Electrical Control

- Custom engineered control panels

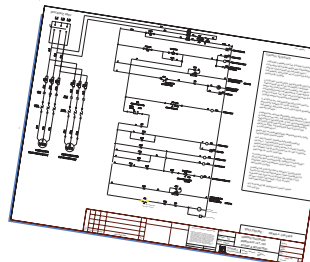

Many more available

LOCATIONS WORLDWIDE

Manufacturing & Service

Americas

Tuthill Vacuum & Blower Systems
4840 West Kearney Street
Springfield, Missouri USA 65803-2602
Tel (417) 865-8715 (800) 825-6937
Fax (417) 865-2950
<http://vacuum.tuthill.com>

Europe/Middle East/Africa

Tuthill Vacuum & Blower Systems/Europe
Pennine Business Park, Pilsworth Road
Heywood, Lancashire, OL10 2TL, England
Tel (44) 01706 362 400 Fax (44) 01706 362 444

Asia/Pacific

Shanghai Kinney Vacuum Equipment Co. Ltd.
3516 Wai Qing Song Highway
Shanghai, China 201709
Tel 86-21-5974 5418 Fax 86-21-5974 4905

International Sales Offices

Tuthill Europe

Parc Industriel Wavre Nord
Avenue Vésale, 30 – 1300 Wavre – Belgium
Phone: 32.10.22.83.34
Fax: 32.10.22.83.38
Email: tld@tuthill.com

Tuthill Asia Pacific

19-21 Milton Park, 128 Canterbury Road
Box 71, Kilsyth, Victoria 3137 Australia
Phone: 61.3.9720.6533
Fax: 61.9.9720.6880
Email: asiapacific@tuthill.com.au

Tuthill Latin America

1320 South Dixie Highway, Suite 761
Coral Gables, Florida 33146 USA
Phone: 305-740-3381
Fax: 305-740-9328
Email: tuthill.latinamerica@tuthill.com

Tuthill China

Room 1507 – Harbour Ring Plaza
No. 18 Xizang Zhong Road
Shanghai 200001 China
Phone: 86.21.5385.3369
Fax: 86.21.5385.3365
Email: China@tuthill.com.cn

Tuthill Vacuum & Blower Systems (TVBS) is a pioneer in the development of vacuum pump technology. Introduced in 1926, the Kinney® rotary piston vacuum principle still sets the industry standard for high performance, reliability, low maintenance and quiet operation in a mechanical vacuum pump design. These same performance features are demonstrated in all the TVBS vacuum pump product lines: liquid ring pumps, dry pumps, vane pumps and our main line of rotary piston pumps. In addition, all pump designs can be incorporated in complete TVBS-engineered vacuum systems.

For information and specifications on other Kinney Vacuum Pumps and Systems, please contact us at 1-800-825-6937.

