

T650

T R U C K B L O W E R

Revolutionary Dry Bulk Truck Blower
for Conveying Cement, Powders
and General Purpose Products.



TUTHILL
Vacuum & Blower Systems





T650

TRUCK BLOWER

A New Twist in Truck Blower Technology.

The T650 truck blower is a new product from the company that has pioneered and produced thousands of truck blowers since 1959. The T650 is a rotary screw machine with 25 psi capability. It has no wearing vanes and is engineered to meet the fast off-loading needs of the construction industry, known for demanding applications.

Specifications:

Air Flow	260 – 565 CFM
Pressure	25 psi continuous
Vacuum	17" HG continuous and up to 425 CFM
Blower Wt.	265 pounds
Warranty	12 months

Applications include:

- Cement
 - Fly ash
 - Hydrated lime
 - Pulverized limestone
 - Sand
 - Barite
 - Calcium carbonate
 - Clay
 - Perlite
- Also flour, starch and sugar.

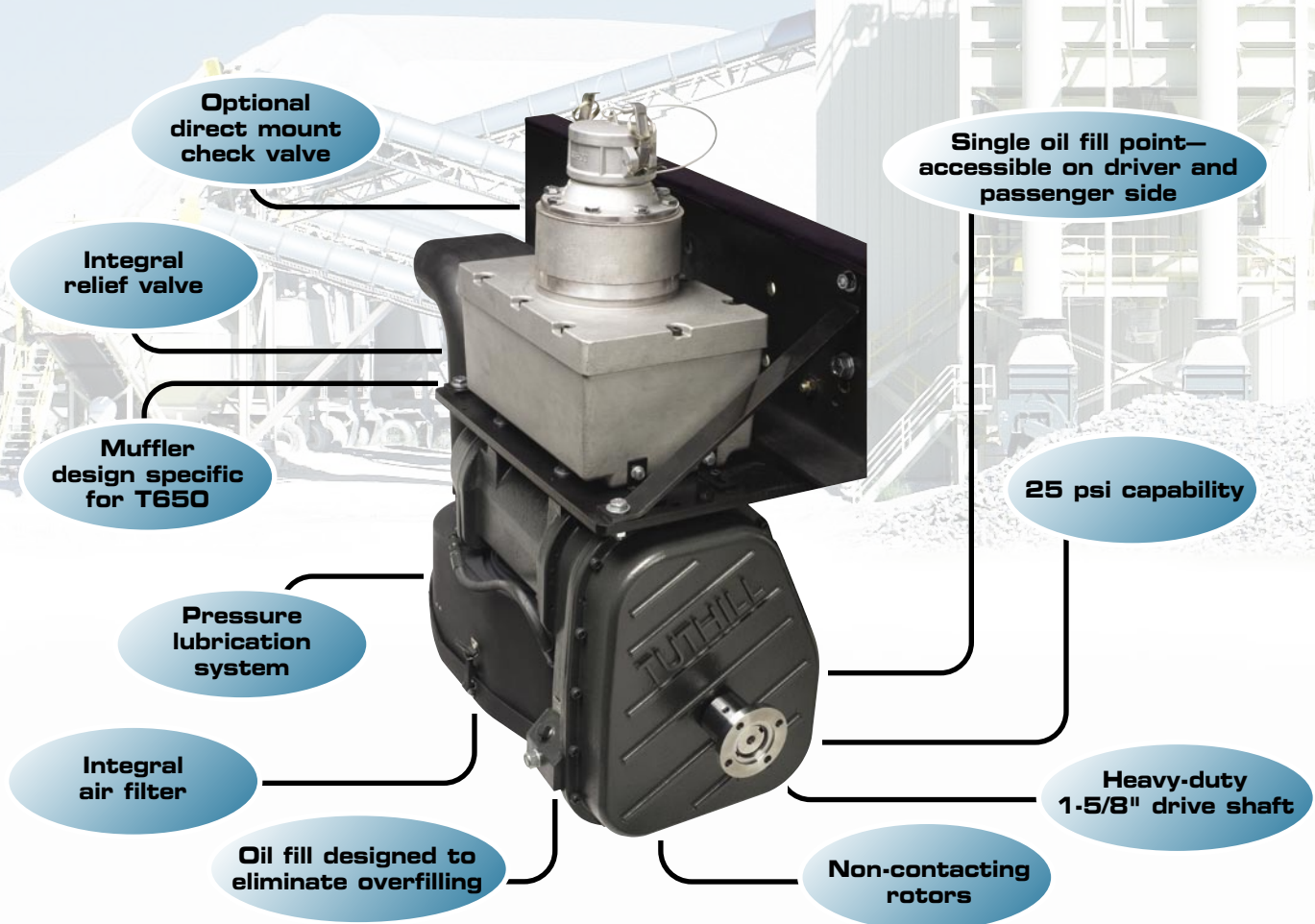

T650

TRUCK BLOWER



Specifications

T650 PRESSURE CURVE

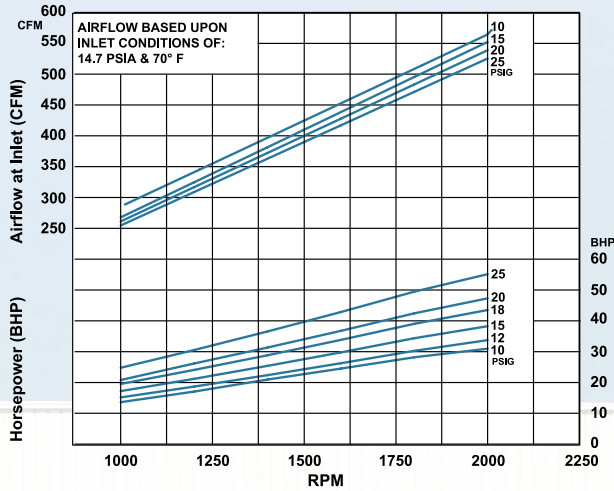

T650 VACUUM CURVE

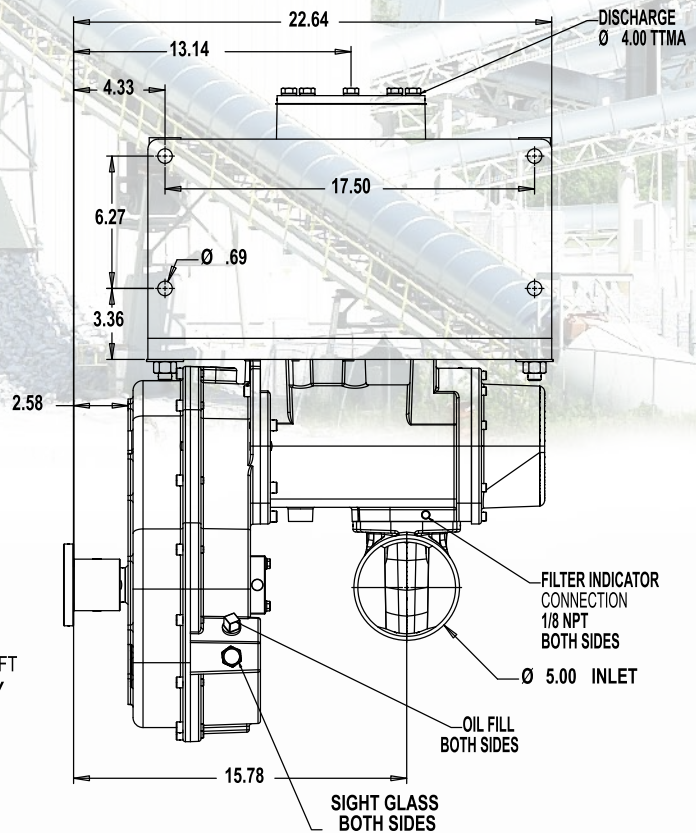
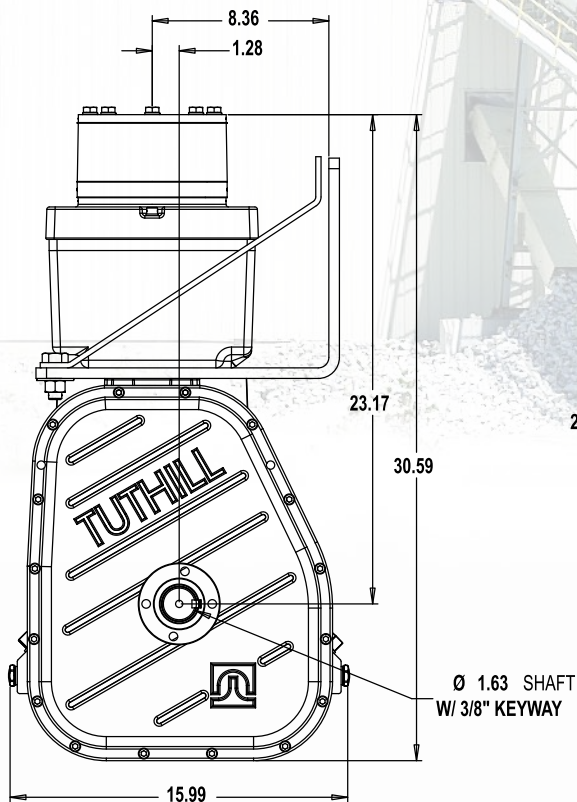
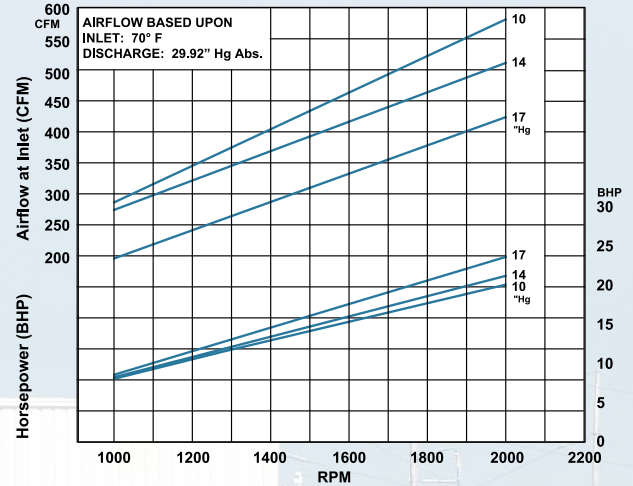



Integral Air Filter

- Mounts under blower and not on frame rail
- Provides more space on frame rail for fuel tanks, steps or emission controls
- Quick change element



Traditional Mount Air Filter

- Standard filter kit
- High capacity
- For severe duty (dusty) environments



Muffler Designed Specifically For T650

- Hidden beneath deckplate
- Incorporates pre-set relief valve, no additional pipework needed
- Replaceable baffle material



Hydraulic Drive Options Available

- 2 bolt SAEB mount
- 4 bolt SAEB mount
- 4 bolt SAEC mount
- Hydraulic drive allows operator to mount blower in any convenient location, tractor or trailer

12-Month Limited Warranty

Each new T650 is factory tested and carries a factory warranty for 12 months from date of initial use or 18 months from date of shipment to first purchaser, whichever occurs first. Tuthill Vacuum & Blower Systems warrants its T650 model truck blower to be free from defects in materials or workmanship.

Call **1-800-825-6937** for the nearest distributor or visit <http://vacuum.tuthill.com> or www.truckblowers.com.



TUTHILL
Vacuum & Blower Systems

4840 West Kearney Street, Springfield, Missouri USA 65803-8702
1-800-825-6937 • 417-865-8715
Fax: 417-865-2950
<http://vacuum.tuthill.com> or www.truckblowers.com



Distributed By: