

# T950H

TRUCK COMPRESSOR

Revolutionary Dry Bulk Truck Compressor  
for Conveying Cement, Powders  
and General Purpose Products.



**TUTHILL**  
Vacuum & Blower Systems





# T950H

TRUCK COMPRESSOR

## A New Twist in Truck Compressor Technology.

The T950H truck compressor is a new product from the company that has pioneered and produced thousands of truck blowers since 1959. The T950H is a rotary screw machine with 2.2 bar capability. It has no wearing vanes and is engineered to meet the fast off-loading needs of the construction industry, known for demanding applications.

### Specifications:

<b>Air Flow</b>	460 – 1000 m <sup>3</sup> /h
<b>Pressure</b>	2.2 bar continuous
<b>Vacuum</b>	575 mBar @ 722 m <sup>3</sup> /h
<b>Compressor Wt.</b>	120 KG
<b>Warranty</b>	12 months

### Applications include:

- Cement
  - Fly ash
  - Hydrated lime
  - Pulverized limestone
  - Sand
  - Barite
  - Calcium carbonate
  - Clay
  - Perlite
- Also flour, starch and sugar.

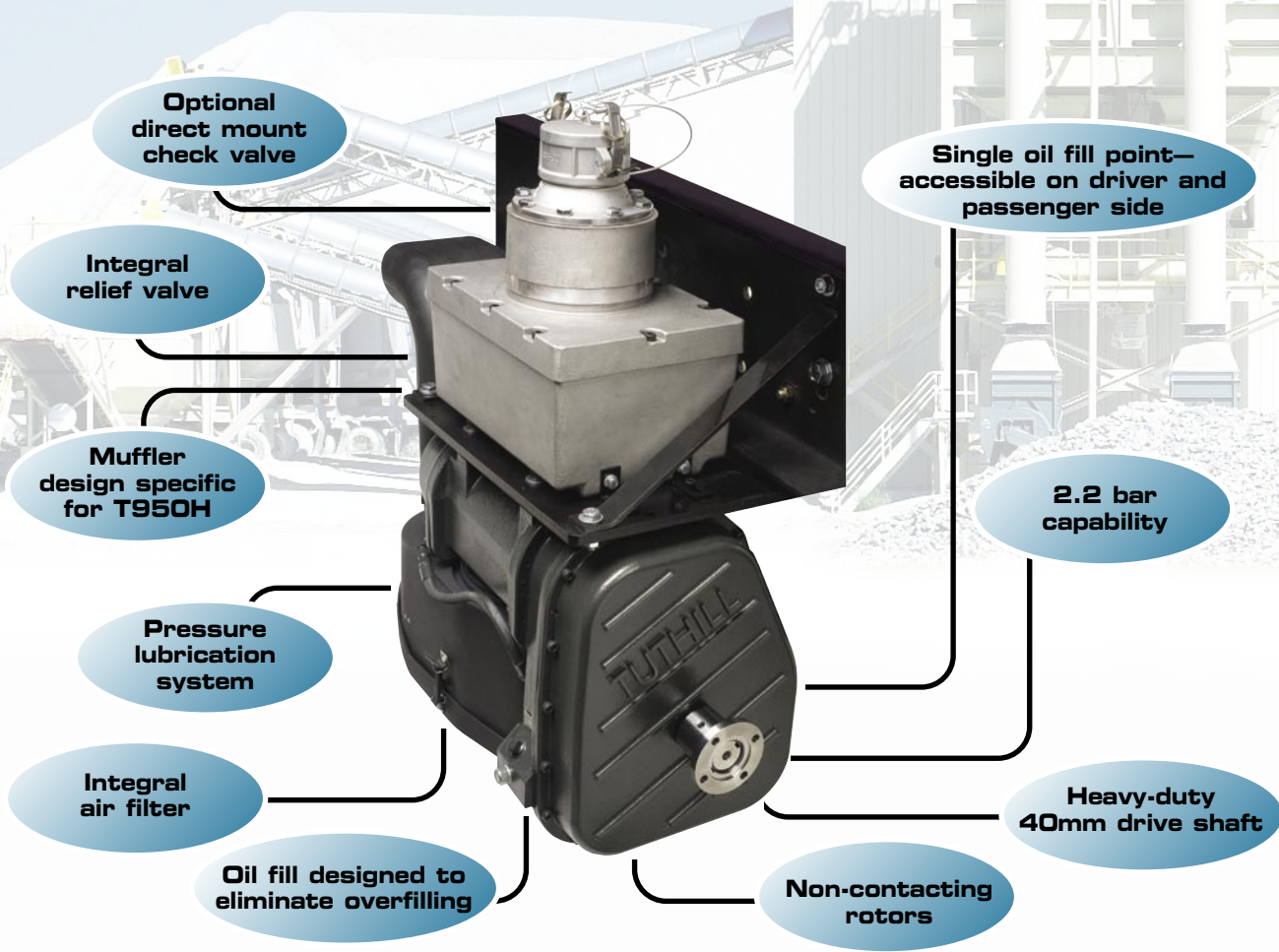

# T950H

TRUCK COMPRESSOR

## Specifications



T950H PRESSURE CURVE

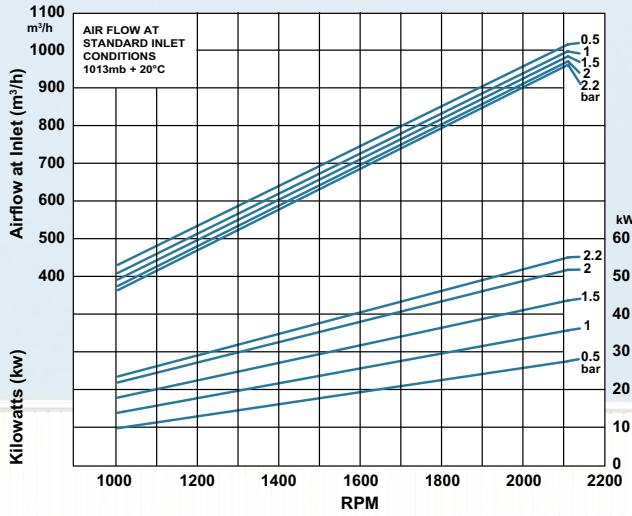

T950H VACUUM CURVE

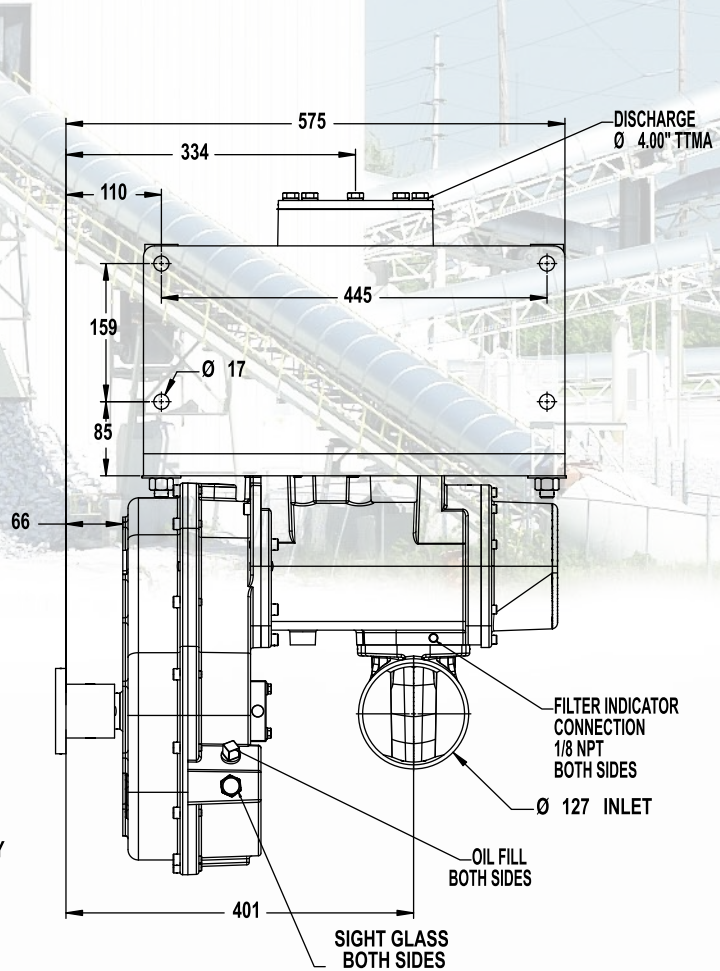
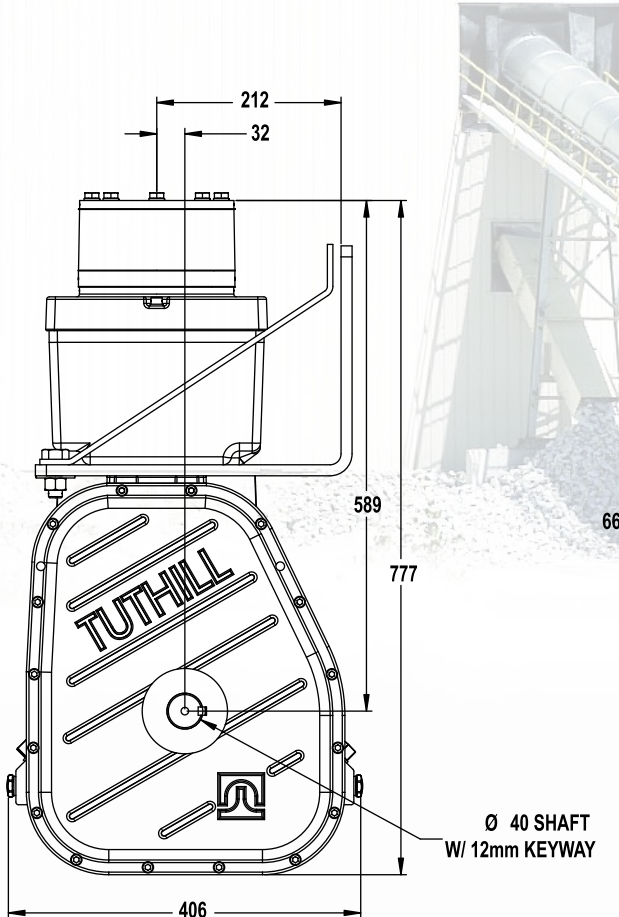
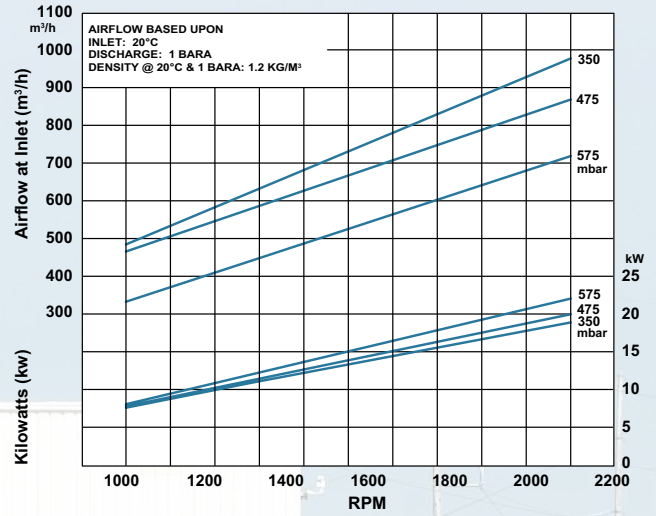

# T950H

TRUCK COMPRESSOR

## Compressor Technology



### Integral Air Filter

- Mounts under compressor and not on frame rail
- Provides more space on frame rail for fuel tanks, steps or emission controls
- Quick change element



### Traditional Mount Air Filter

- Standard filter kit
- High capacity
- For severe duty (dusty) environments



### Muffler Designed Specifically For T950H

- Hidden beneath deckplate
- Incorporates pre-set relief valve, no additional pipework needed
- Replaceable baffle material



### Hydraulic Drive Options Available

- 2 bolt SAEB mount
- 4 bolt SAEB mount
- 4 bolt SAEC mount
- Hydraulic drive allows operator to mount compressor in any convenient location, tractor or trailer

### 12-Month Limited Warranty

Each new T950H is factory tested and carries a factory warranty for 12 months from date of initial use or 18 months from date of shipment to first purchaser, whichever occurs first. Tuthill Vacuum & Blower Systems warrants its T950H model truck blower to be free from defects in materials or workmanship.

Call **1-800-825-6937** for the nearest distributor or visit <http://vacuum.tuthill.com> or [www.truckblowers.com](http://www.truckblowers.com).



4840 West Kearney Street, Springfield, Missouri USA 65803-8702  
1-800-825-6937 • 417-865-8715  
Fax: 417-865-2950  
<http://vacuum.tuthill.com> or [www.truckblowers.com](http://www.truckblowers.com)



**Distributed By:**