

TUTTHILL

T R U C K B L O W E R S

Revolutionary Dry Bulk Truck Blowers
for Conveying Cement, Powders, Food Products,
Pebbles and General Purpose Products.



 **Tuthill**



T650

TRUCK BLOWERS

A New Twist in Truck Blower Technology



The T650 truck blower is a new product from the company that has pioneered and produced thousands of truck blowers since 1959. The T650 is a rotary screw machine. It has no wearing vanes and is engineered to meet the fast off-loading needs of the construction industry, known for demanding applications.

Specifications:

Air Flow	260 – 565 CFM
Pressure	25 psi continuous
Vacuum	17" HG continuous and up to 425 CFM
Blower Wt.	265 pounds
Warranty	12 months

Applications include:

- Cement
 - Fly ash
 - Hydrated lime
 - Pulverized limestone
 - Sand
 - Barium
 - Calcium carbonate
 - Clay
 - Perlite
- Also flour, starch and sugar.

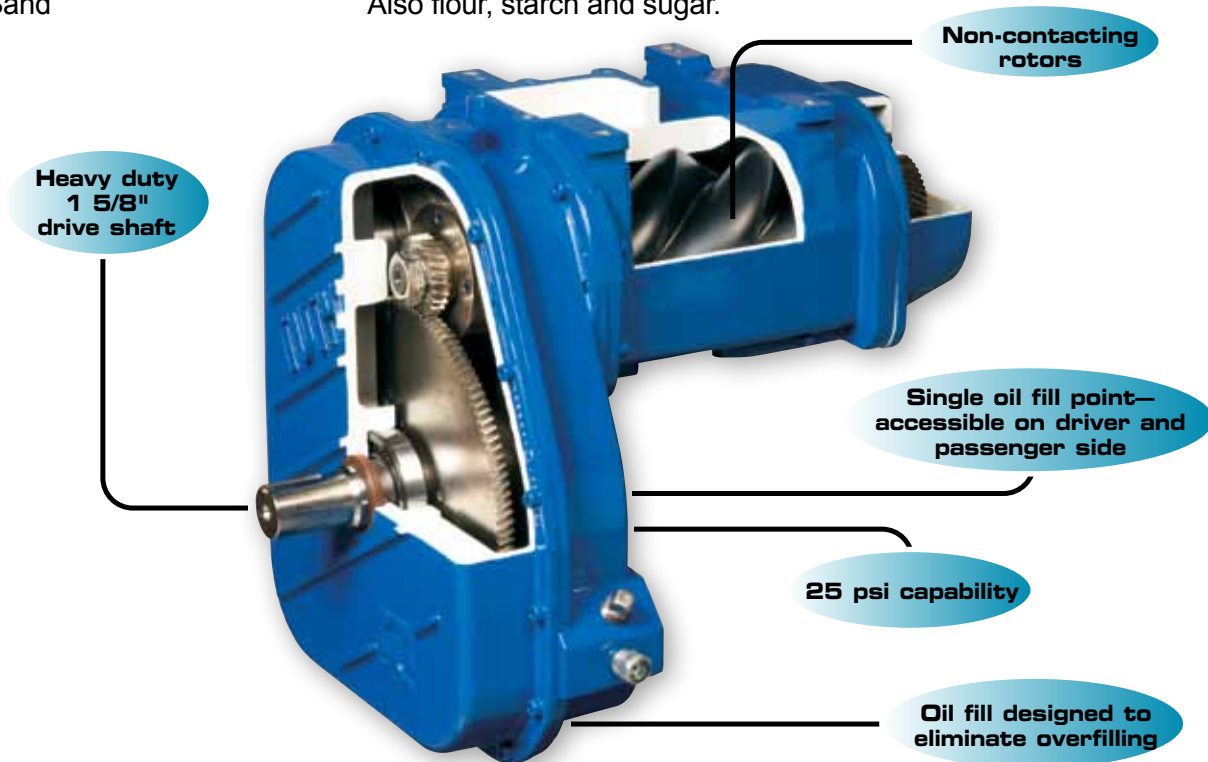

Hydraulic Drive Option Available



CURVES AND DIMENSIONAL DRAWINGS

T650 Truck Blowers

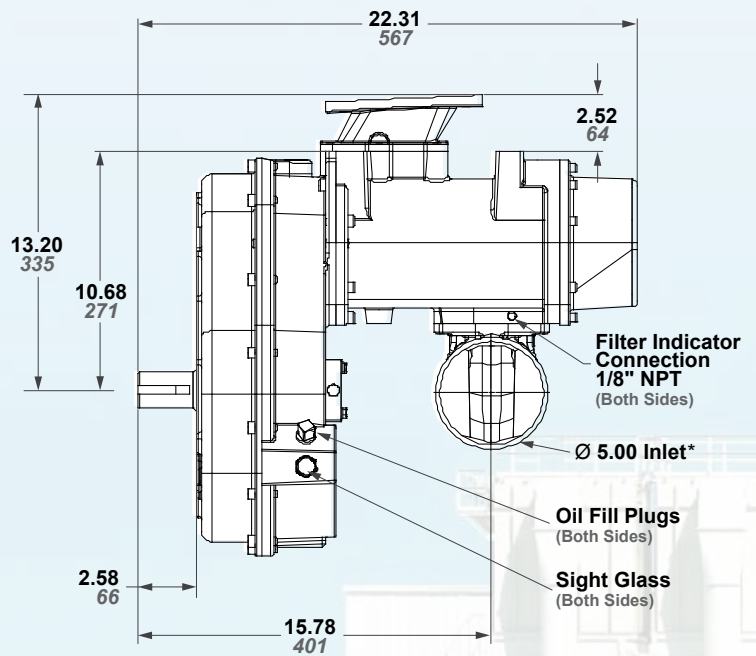
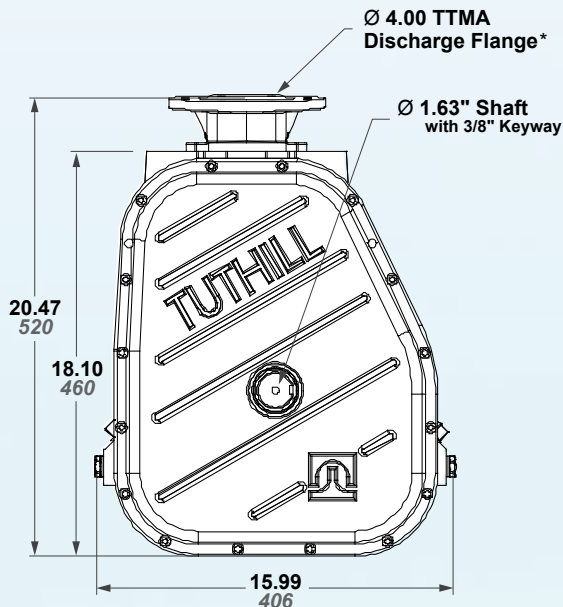
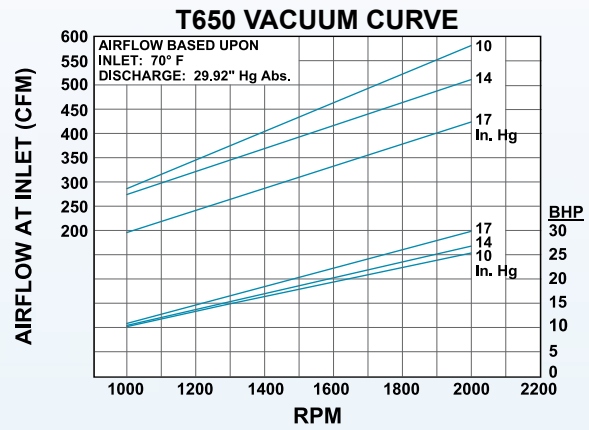
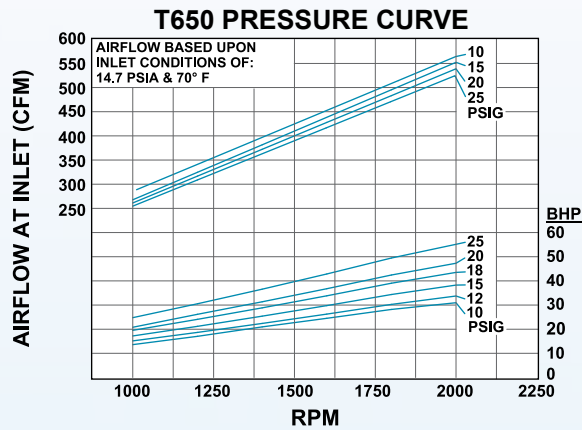

* Purchased Separately



CURVES AND DIMENSIONAL DRAWINGS

T850 & T1050 Truck Blowers

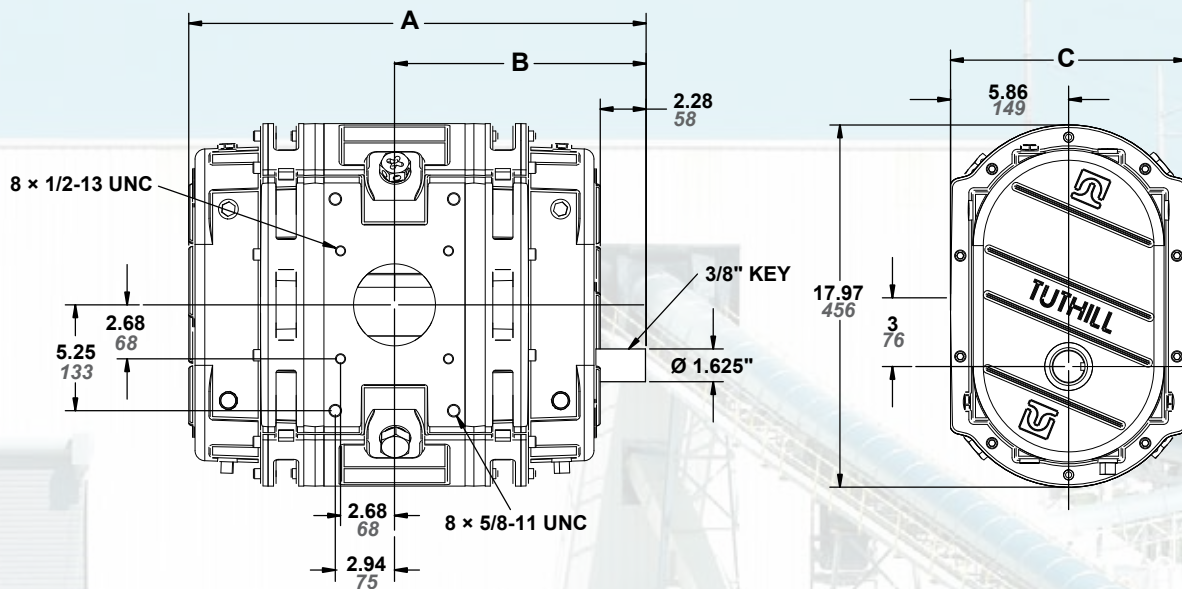
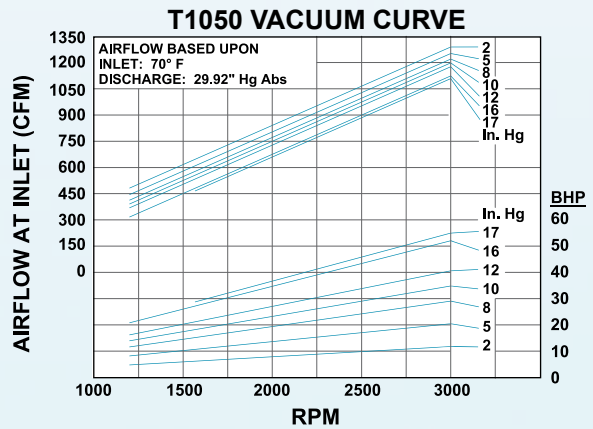
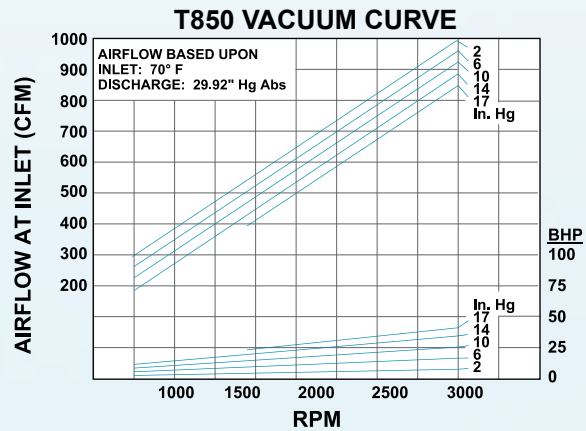
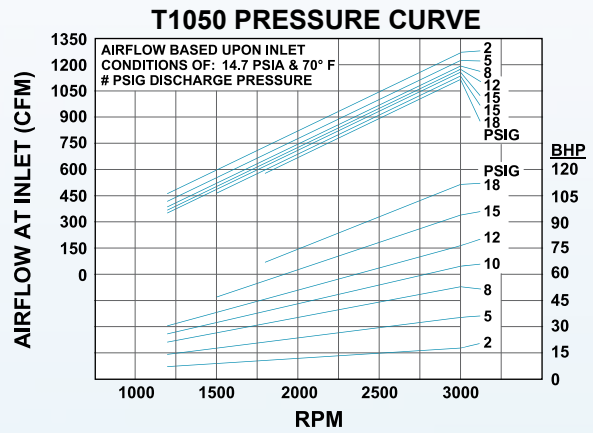
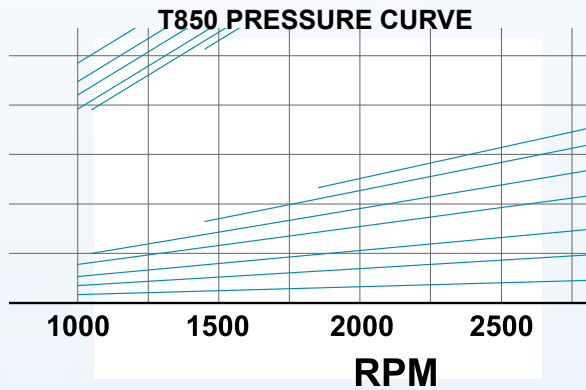

MODEL	A	B	C
T850	22.69 576	12.48 317	11.72 298
T1050	25.19 640	13.73 349	12.13 308

NOTE: The T850 and T1050 standard models do not have external breathers. The breather is internal to the machine.

T850 & T1050

TRUCK BLOWERS



Versatile

The T850 & T1050 are highly versatile and able to unload a variety of products from fine powders to food products to pebbles. With strong features including oil tanks at both ends, wide speed and flow capabilities, large drive shaft and bearings, and 20 psi capability, the T850 & T1050 are built tough for long lasting performance.

Quiet

T850s & T1050s are engineered with built-in silencing chambers for noise reduction.

T850 Specifications:

Air Flow	390 – 1000 CFM
Pressure	20 psi continuous
Vacuum	15" HG continuous
Blower Wt.	340 pounds
Warranty	12 months

T1050 Specifications:

Air Flow	450 – 1000 CFM
Pressure	18 psi continuous
Vacuum	18" HG continuous
Blower Wt.	380 pounds
Warranty	12 months

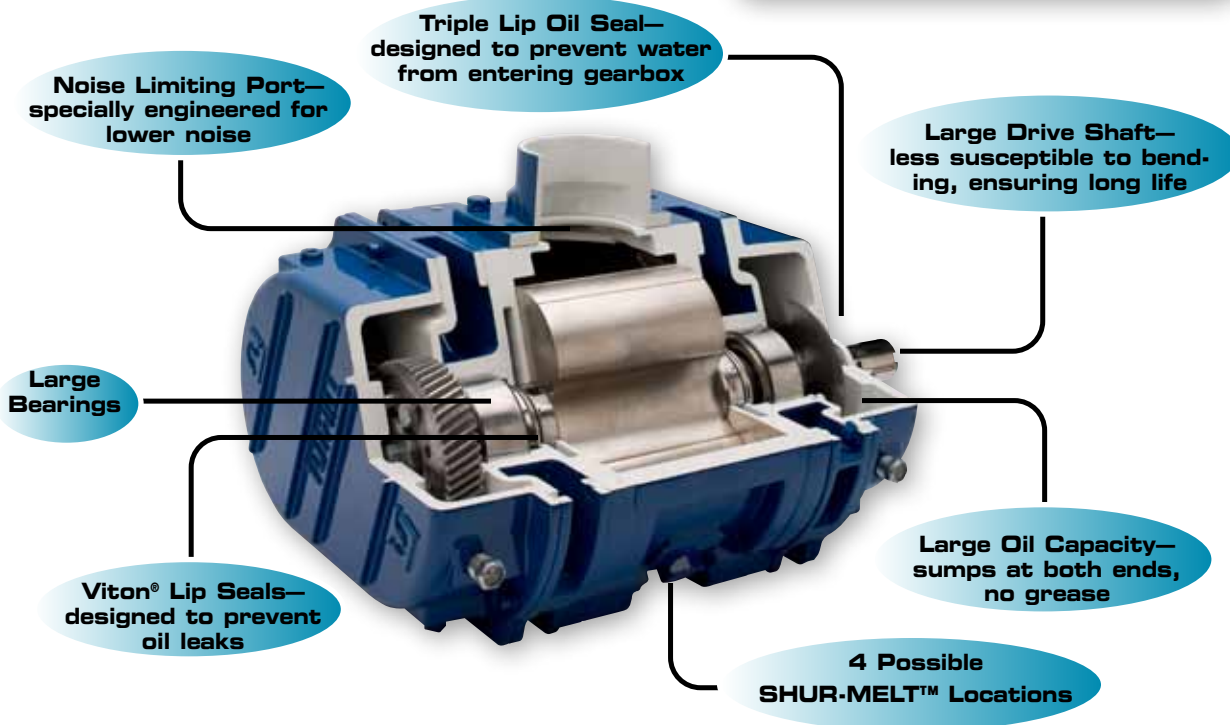

Hydraulic Drive and Dual Shaft Options Available

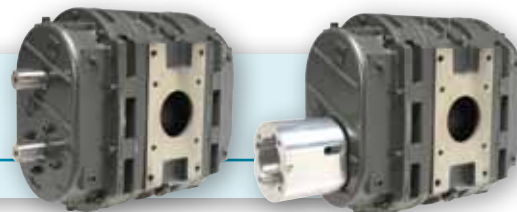

TUTHILL

TRUCK BLOWERS

SHUR-MELT™ Plugs

All T850 & T1050 blowers are specially equipped with two of our patented SHUR-MELT thermal relief plugs for heat and pressure protection. Upon activation, plugs will relieve 5-6 psig with a corresponding 80-100° F discharge temperature drop to protect the blower from damage. Plugs are located on the intake and discharge side of the blower.



Packaged Units

All Tuthill truck blowers are available as packaged units complete with components selected specifically for your application. Electric or engine driven options are also available. For more information, please call 1-800-825-6937 for the distributor nearest you.

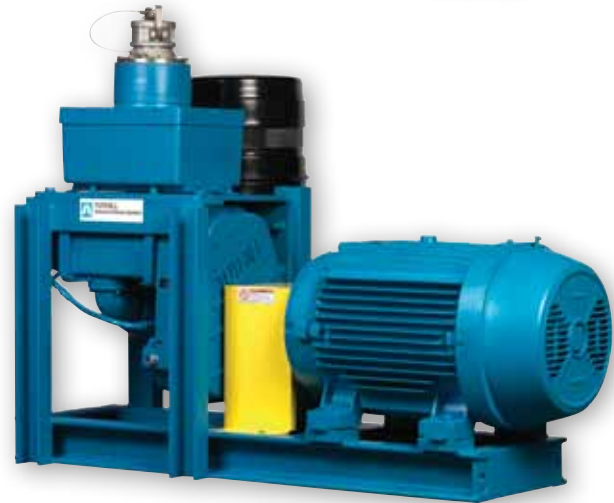

12-Month Limited Warranty

Each new T650, T850 and T1050 is factory tested and carries a factory warranty for 12 months from date of initial use or 18 months from date of shipment to first purchaser, whichever occurs first.

Company History

It's our 50th year manufacturing truck blowers, whether it's rotary positive displacement blowers or blower packages, Tuthill leads the search for innovative solutions. Since 1937, Tuthill has been manufacturing proven blower products that are solidly engineered, competitively priced and produced under stringent ISO 9001 quality standards. Our experience and expertise position us as one of the leading manufacturers of rotary lobe blowers and vacuum boosters.

Call **1-800-825-6937** or visit www.tuthill.com for the representative nearest you.



4840 West Kearney Street
Springfield, Missouri USA 65803-8702
1-800-825-6937 • Fax: 417-865-2950
www.tuthill.com



Distributed By: